

DW30

Wheel Dumpers



**WACKER
NEUSON**
all it takes!



Compact, safe and a real all-rounder

The compact and sturdy wheel dumper DW30 increases not only productivity in materials handling but also, thanks to innumerable safety features, the safety of the operator and of the entire construction site. The 4 wheel drive as well as the constant tractive force combined with the articulated pendulum joint and gradeability of up to 50% make the DW30 a real off- and on-road pro. At the same time, its low service and maintenance costs are impressive. Thanks to the stage 5 engine, all exhaust emissions specifications are fulfilled even without a diesel particulate filter. A 36 kW engine is also available which gives the DW30 additional power.

- The safety cabin provides a strong plus for working in the rain, cold or heat
- Intuitive operation thanks to the joystick operating concept and clearly laid-out dashboard
- Articulated pendulum joint in combination with partial-lock differential for outstanding stability and off-road capability
- High swivel tip skip (optional) with modern tilt sensor
- More power: DW30 power version with an engine performance of 36 kW and auto-stop function

DW30 Technical specifications

	Front tip skip	Swivel tip skip	High swivel tip skip	Concrete skip
Operating data				
Payload kg	3,000	3,000	3,000	3,000
Shipping weight kg	1,987	2,142	2,804	2,574
Shipping weight cabin kg		2,674	3,004	2,759
Shipping weight power kg		2,474		
Operating weight kg	2,098	2,253	2,915	2,685
Operating weight cabin kg		2,785	3,115	2,870
Skip capacity struck l	1,420	1,280	1,280	1,280
Skip capacity heaped l	1,800	1,750	1,750	1,750
Skip capacity water volume l	1,110	990	990	1,200
Engine / Motor				
Engine / Motor manufacturer basic machine	Yanmar	Yanmar	Yanmar	Yanmar
Engine / Motor type	3TNV76	3TNV76	3TNV76	3TNV76
Engine / Motor	Diesel	Diesel	Diesel	Diesel
Engine performance according to ISO 3046/1 kW	18.9	18.9	18.9	18.9
Emission standards stage	5	5	5	5
Displacement cm ³	1,116	1,116	1,116	1,116
Engine RPM rpm	3000	3000	3000	3000
Engine / Motor manufacturer optional engine	Perkins	Perkins	Perkins	Perkins
Engine / Motor type	403J-E17T	403J-E17T	403J-E17T	403J-E17T
Engine performance kW	36	36	36	36
Emission standards stage	5	5	5	5
Displacement cm ³	1,663	1,663	1,663	1,663
Engine RPM rpm	2800	2800	2800	2800
Travel speed km/h	20	20	20	20
Travel speed optional km/h	25	25	25	25
Articulation angle °	36	36	36	36
Pendulum angle °	15	15	15	15
Turning radius mm	3,900	3,900	3,900	3,900
Gradeability %	60	60	60	60
Tires	11.5/80-15.3 Mitas TS-05	11.5/80-15.3 Mitas TS-05	11.5/80-15.3 Mitas TS-05	11.5/80-15.3 Mitas TS-05
L x W x H mm	3,710 x 1,730 x 2,778	3,928 x 1,730 x 2,778	4,071 x 1,780 x 2,860	4,806 x 1,780 x 2,860
L x W x H mm	3,710 x 1,730 x 2,778	3,928 x 1,730 x 2,778	4,071 x 1,780 x 2,860	4,806 x 1,780 x 2,860
Steering pump	Axial piston pump	Axial piston pump	Axial piston pump	Axial piston pump

	Front tip skip	Swivel tip skip	High swivel tip skip	Concrete skip
Flow rate l/min	66	66	66	66
Operating pressure bar	445	445	445	445
Duty pump	Gear pump	Gear pump	Gear pump	Gear pump
Flow rate l/min	33.4	33.4	33.4	33.4
Operating pressure bar	200	200	200	200
Fuel tank capacity l	35	35	35	35

DW30 Dimensions

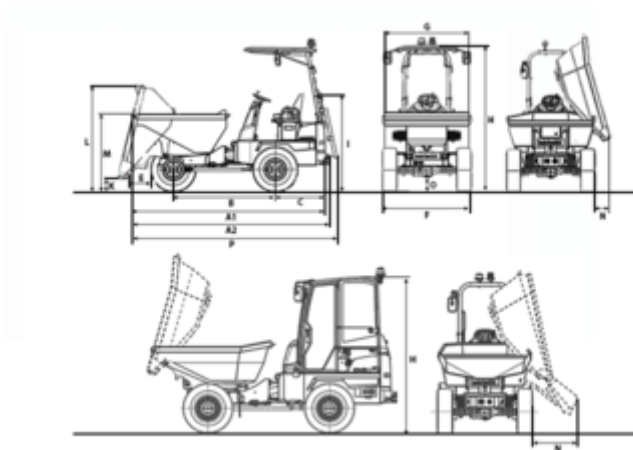

		Front tip skip	Swivel tip skip	Swivel tip skip with Power-Engine	High-swivel tip skip	Concrete edition
A1	Overall length 4,071 mm	4,608 mm		3,710 mm	3,928 mm	4,139 mm
A2	Overall length with towing hitch 4,156 mm	4,684 mm		3,786 mm	3,904 mm	4,223 mm
B	Wheelbase 2,090 mm	1,945 mm		1,945 mm	1,945 mm	2,090 mm
C	Rear overhang 1,072 mm	963 mm		963 mm	963 mm	1,072 mm
E	Dumping distance 492 mm	629 mm		543 mm	482 mm	539 mm
F	Width 1,780 mm	1,730 mm		1,730 mm	1,730 mm	1,780 mm
G	Skip width 1,730 mm	1,740 mm		1,730 mm	1,730 mm	1,730 mm
H	Height roll over protection system (ROPS) 2,860 mm	2,778 mm		2,778 mm	2,778 mm	2,860 mm
I	Height roll over protection system (ROPS) folded down 1,945 mm	1,913 mm		1,913 mm	1,913 mm	1,945 mm
J	Height cabin 2,669 mm	2,669 mm		2,669 mm	2,669 mm	2,669 mm
K	Dump height max. 1,268 mm	363 mm		233 mm	994 mm	994 mm
K	Dump height max. 1,929 mm					
L	Skip height tipped skip 3,342 mm	3,308 mm		2,074 mm	3,082 mm	3,082 mm
L	Skip height					

	Hochdrehkippmulde angehoben 3,915 mm			
M	Skip height 1,639 mm	1,698 mm	1,473 mm	1,475 mm
M	Skip height Hochdrehkippmulde angehoben 2,212 mm			
N	Dumping distance sideways 162 mm	852 mm	235 mm	210 mm
O	Ground clearance 257 mm	257 mm	257 mm	257 mm
P	Length roll over protection system (ROPS) folded down 4,326 mm	4,825 mm	3,927 mm	4,045 mm
--	Dump angle 46 °	62 °	48 °	48 °

Please note: that product availability can vary from country to country. It is possible that information / products may not be available in your country. More detailed information on engine power can be found in the operator's manual; the stated power may vary due to specific operating conditions. Subject to alterations and errors excepted. Applicable also to illustrations.
Copyright © 2021 Wacker Neuson SE.